

版本	A/0
----	-----

REV	REVISIONS REC	DATE

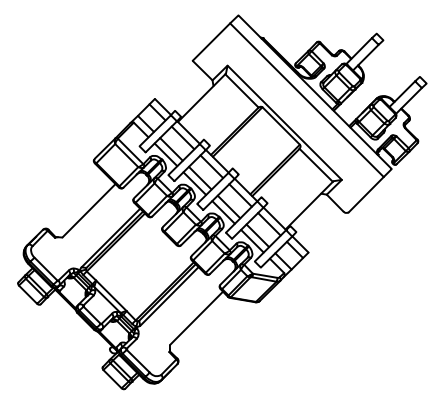

注：“★”为重点尺寸,未注明R角为0.3.

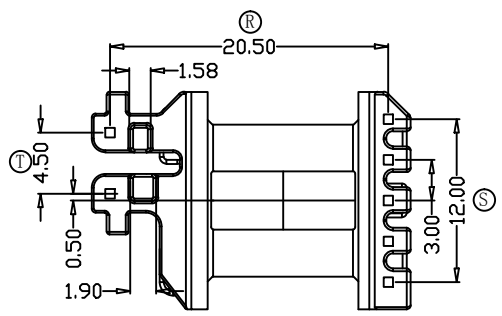
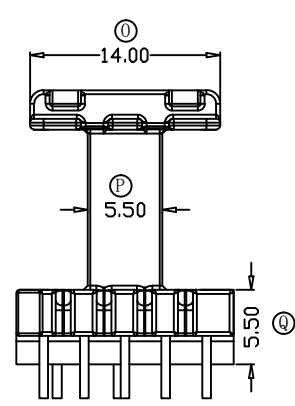
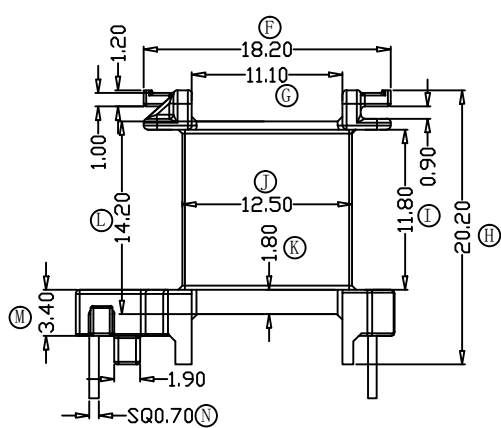
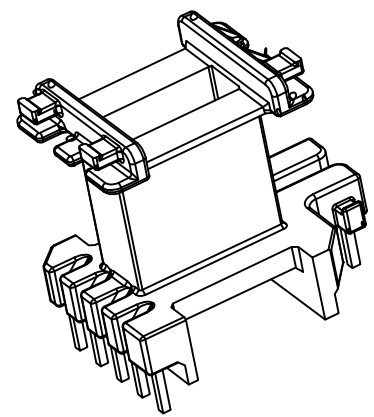
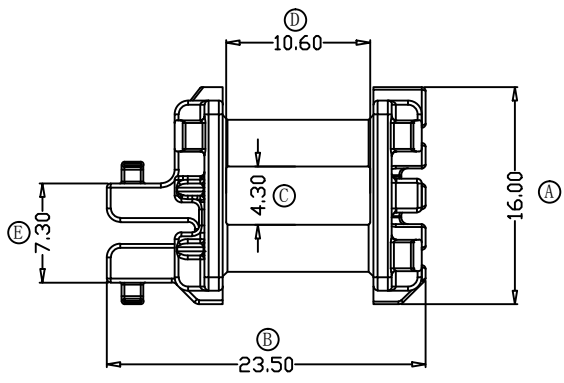

深圳市搏思康电子有限公司  
SHENZHEN BOSCOM ELECTRONICS CO.,LTD

型号 MODEL NAME		产品编号 DRAWING NO	
EE-16 (5+2P)		B-1618	
MATERIAL	PM-9820	PIN MATERIAL:	符合ROHS/HF要求
SCALE	FIT	CP WIRE	符合UL94V-0标准
DRWING	22/01/2016	TOLERANCE	
DESIGNED		0<L<4	±0.10
APPROVED		4≤L≤16	±0.20
		16以上	±0.30
		壁厚:	±0.10
		PIN径:	±0.05

ADDRESS	深圳市观澜街道石马径社区君新路石三工业区146号
TELEPHONE	0755-28032969 28032970 28032971
FAX	0755-28032965