

版本:	A/1	REV.	REVISIONS REC.	DATE
		A/0	PL2.25±0.2变更为1.7±0.15mm	2020.11.04
		A/1	⊕尺寸由6.50 ^{+0.15} _{-0.20} 变更为6.50 ^{+0.25} _{-0.20}	2020.12.02
			Ⓜ尺寸由SQ0.5变更为SQ0.45	2020.12.02

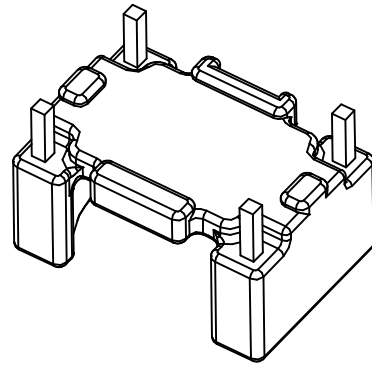

注：量产模

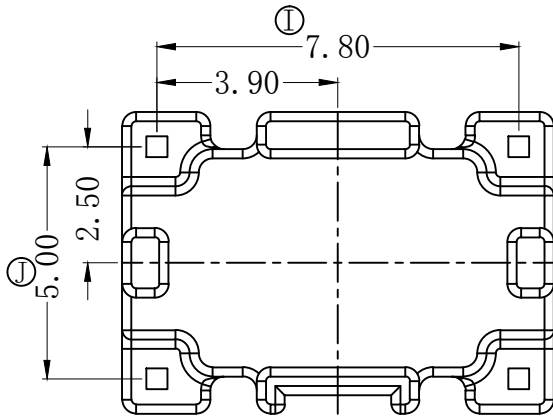
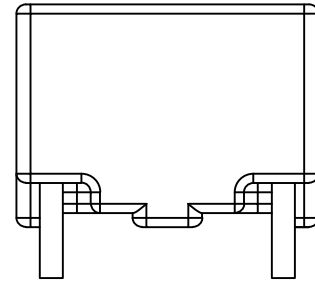
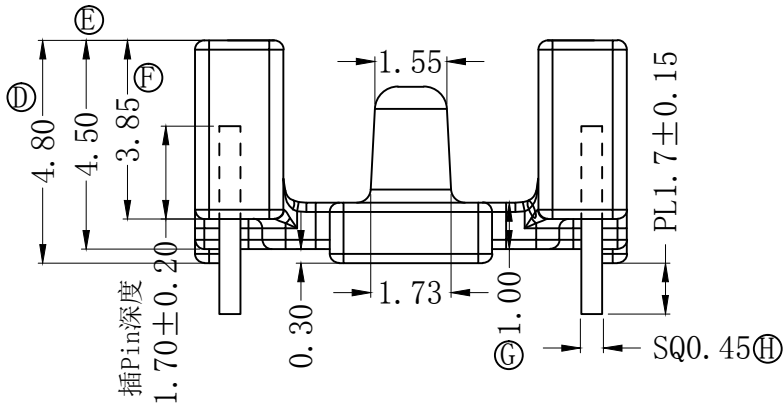
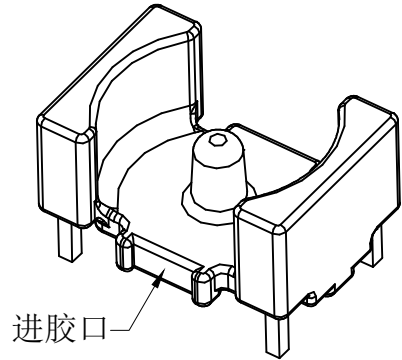
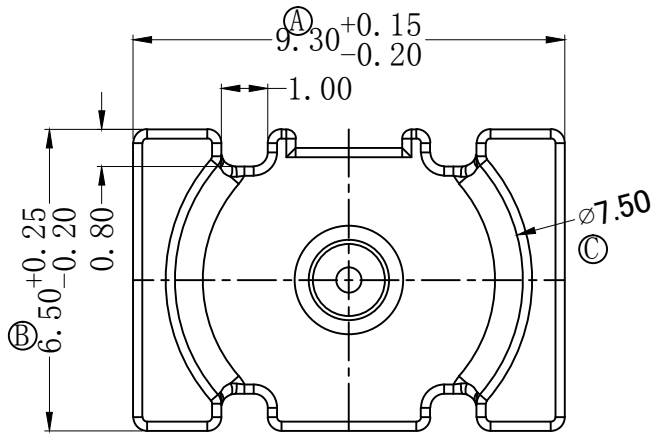

深圳市搏思康电子有限公司
SHENZHEN BOSCOM ELECTRONICS CO.,LTD

ADDRESS	深圳市观澜街道石马径社区君新路石三工业区146号	型号 MODER NAME		产品编号 DRAWING NO	
		BASE (2+2P)		B-B165	
TELEPHONE	0755-28032969 28032970 28032971	MATERIAL	PM-9823	PIN MATERIAL:	符合ROHS/HF要求
		SCALE	FIT	CP WIRE	符合UL94V-0标准
FAX	0755-28032965	DRWING	02/12/2020	TOLERANCE	
		DESIGNED	张直洪	0<L≤4 ±0.10	
		APPROVED		4<L≤16 ±0.20	
				16以上 ±0.30 PIN径: ±0.05	