

# 量产模

版本: A/0	REV.	REVISIONS REC.	DATE
---------	------	----------------	------

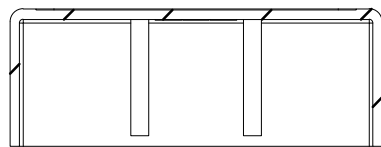
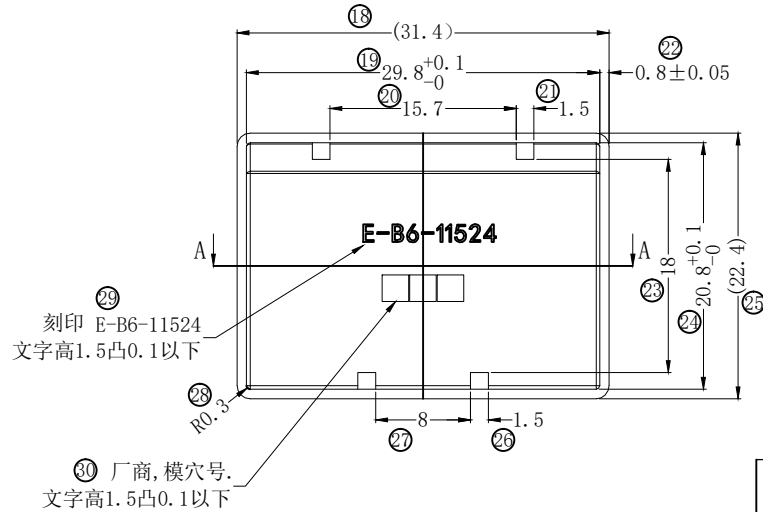
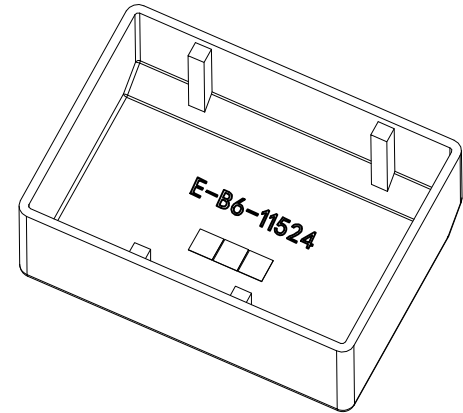
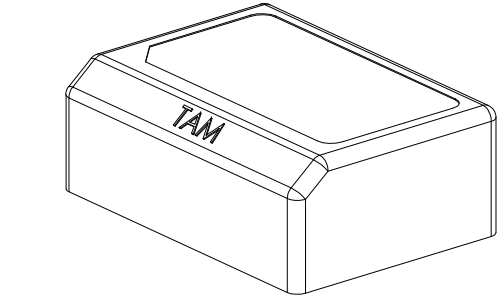
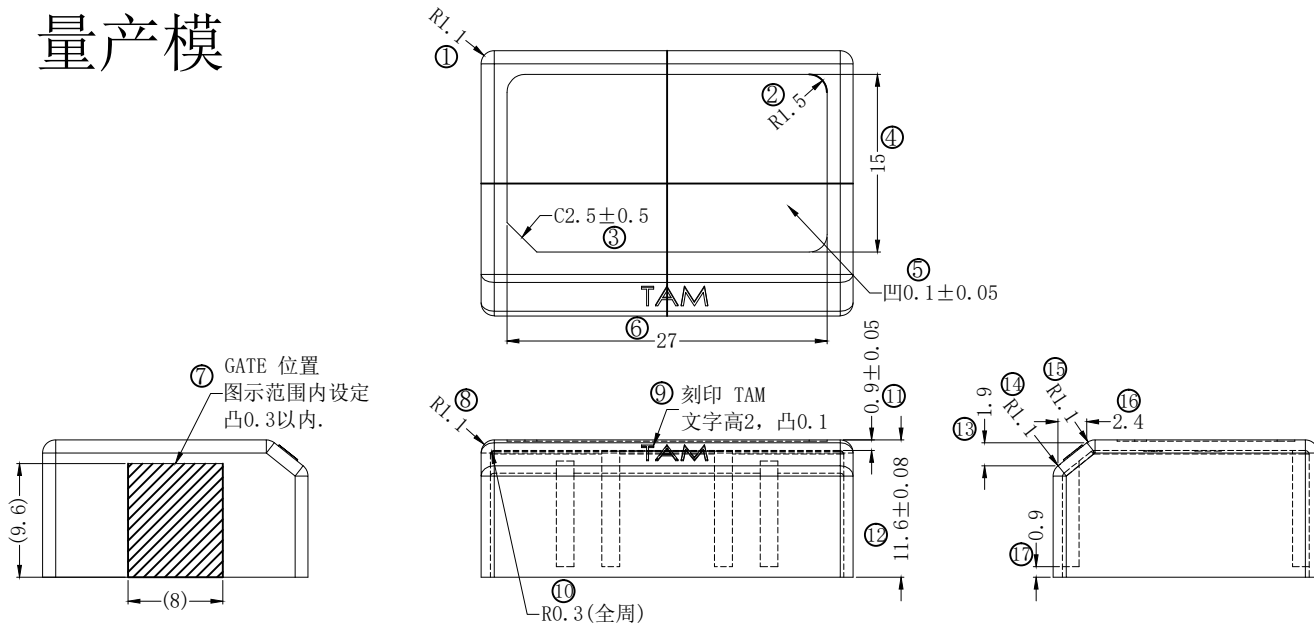

SECTION A-A

客户料号: E-B6-11524

深圳市搏思康电子有限公司 SHENZHEN BOSCOM ELECTRONICS CO.,LTD		型号 MODEL NAME		产品编号 DRAWING NO	
ADDRESS: 深圳市龙华区观澜街道牛湖社区君新路164号		CASE		B-28103-1	
TELEPHONE: 0755-29673660 29673519		MATERIAL	PBT-1184G30BK	PIN	CP WIRE
广东搏思远科技有限公司 Guangdong Bosyuan Technology Co.,Ltd		SCALE	FIT	TOLERANCE	
ADDRESS: 河源市高新区富民工业园A区联体厂房A栋南栋		DRWING	25/04/2022	0<L≤4 ±0.05	
TELEPHONE: 0762-2820657 2820658 2820659 2820660		DESIGNED	庄永委	4<L≤20 ±0.08	
		APPROVED		20<L≤50 ±0.10	
				50<L≤200 ±0.15	